

TOOLS FOR CONSTRUCTION SITES
WERKZEUGE FÜR DAS BAUWERBE
OUTILLAGE POUR L'INDUSTRIE DU BÂTIMENT

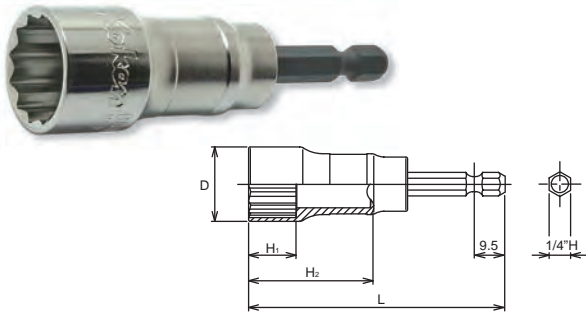

Z-SERIES
 HAND
 TITANIUM
 SCREWDRIVERS ACCESSORIES
 IMPACT
 SLEEVE-DRIVE
 PROTECTOR
 INDUSTRIAL
 AUTOMOTIVE
 MOTORCYCLE
 CONSTRUCTION
 SPARE PART

BD014SE ○ 12-point Nut Setters
 12-kant Steckschlüsselklingen
 Douilles 12-pans à embout



BD014SE (mm)	D (mm)	H ₁ (mm)	H ₂ (mm)	L (mm)	(g)	(pcs.)
8	12	12	36	77	35	10
10	14	12	36	77	38	10
12	16.5	14	36	77	48	10
13	17.5	14	36	77	51	10
14	19	14	36	77	54	10
17	22.5	14	36	77	76	10
19	24.5	14	36	77	83	10
21	27	14	34	77	104	10
22	28	14	34	77	120	10
24	30.3	14	34	77	140	10

● DIN 3126 Form E 6.3

BD014E ○ 12-point Nut Setters, deep
 12-kant Steckschlüsselklingen, lang
 Douilles longues, 12-pans à embout

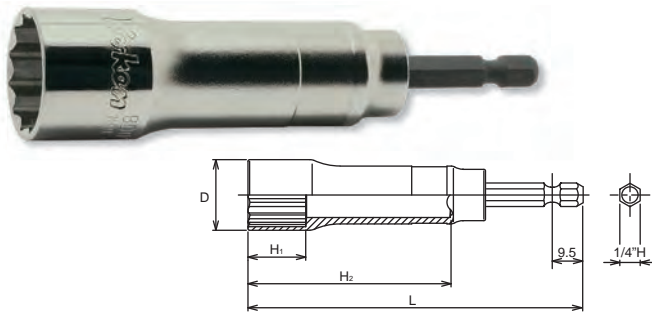

BD014E (mm)	D (mm)	H ₁ (mm)	H ₂ (mm)	L (mm)	(g)	(pcs.)
8	12	12	63	104	45	10
10	14	12	63	104	52	10
12	16.5	18	63	104	61	10
13	17.5	18	63	104	65	10
14	19	18	63	104	72	10
17	22.5	18	60	104	80	10
19	24.5	18	60	104	95	10
21	27	18	60	104	110	10
22	28	18	60	104	112	10
24	30.3	18	60	104	123	10

● DIN 3126 Form E 6.3

BD014E-140 ○ 6-point Nut Setters, extra deep
 6-kant Steckschlüsselklingen, extra lang
 Douilles extra-longues, 6-pans à embout

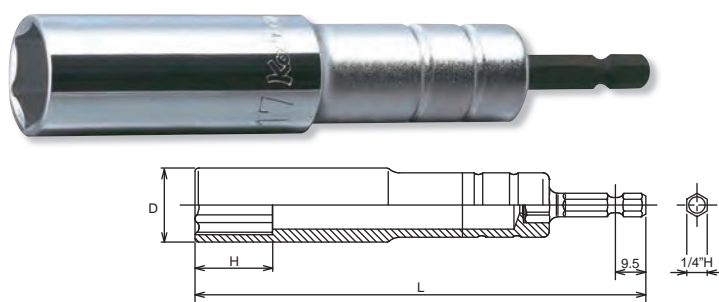

BD014E-140 (mm)	D (mm)	H (mm)	L (mm)	(g)	(pcs.)
13	19	20	140	120	10
17	24	26	140	190	10

● DIN 3126 Form E 6.3

BD042E ○ 6-point Nut Setters deep (Exchangeable Drive Shank)
 6-kant Steckschlüsselklinge lang (austauschbarer Antriebsschaft)
 Jeu d'écrus à 6-pans longues (tige d'entraînement échangeable)

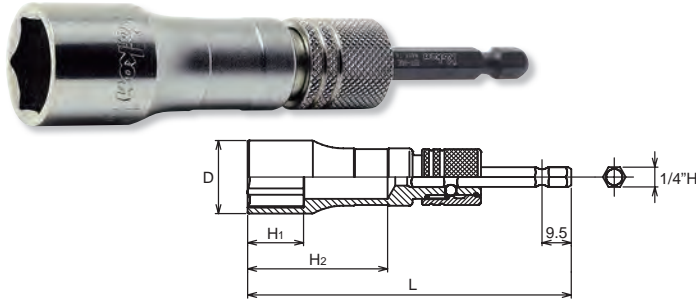

BD042E (mm)	D (mm)	H ₁ (mm)	H ₂ (mm)	L (mm)	(g)	(pcs.)
17	23.5	18	45	111	114	10
19	25.5	18	45	111	119	10
21	28	18	45	111	132	10
24	31.5	18	45	111	147	10

● DIN 3126 Form E 6.3

BIT-60E Drive bit for BD042E
 Antriebsbit für BD042E
 Embout d'entraînement pour BD042E

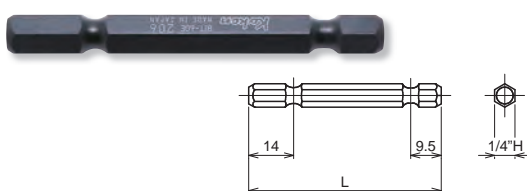

	L (mm)	(g)	(pcs.)
BIT-60E	60	10	10

● DIN 3126 Form E 6.3

BD014XE (mm)	D (mm)	H ₁ (mm)	H ₂ (mm)	L (mm)	(g)	(pcs.)
8SF	13	12	49	90	40	10
10SF	15	12	49	90	46	10
12SF	17.5	14	48	90	54	10
13SF	18.5	14	48	90	58	10
14SF	19.8	14	47	90	64	10
17SF	23.5	14	46	90	81	10
19SF	25.5	14	46	90	100	10
21SF	28	14	46	90	123	10
24SF	31.5	14	45	90	137	10

● DIN 3126 Form E 6.3

BD014E (mm)	D (mm)	H ₁ (mm)	H ₂ (mm)	L (mm)	(g)	(pcs.)
17SF	23.5	18	60	104	94	10
19SF	25.5	18	60	104	100	10
21SF	28	18	60	104	110	10

● DIN 3126 Form E 6.3

BD008E-165 (mm)	D (mm)	H ₁ (mm)	H ₂ (mm)	L (mm)	(g)	(pcs.)
17	22.8	17	110	165	105	10
19	24.8	17	110	165	135	10
21	27.3	17	110	165	142	10

● DIN 3126 Form E 6.3

BD011SE (mm)	D (mm)	H ₁ (mm)	H ₂ (mm)	L (mm)	(g)	(pcs.)
10	14	12	35	100	73	10
12	16.5	12	35	100	77	10
13	17.5	12	35	100	79	10
14	19	12	32	100	82	10
17	22.5	14	32	100	87	10
19	24.5	14	30	100	94	10
21	27	14	30	100	103	10
22	28	14	30	100	104	10

● DIN 3126 Form E 6.3

184E-64	D (mm)	H ₁ (mm)	H ₂ (mm)	L (mm)	(g)	(pcs.)
3/8x24UNF	12.5	14.5	13	64	34	10
1/2x20UNF	12.5	15.5	13	64	40	10

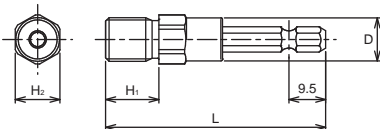

BD014XE-SF

Surface Drive Nut Setters, Semi-Deep
Surface Drive Steckschlüsselklingen, mittel lang
Douilles semi-profondes, Surface Drive

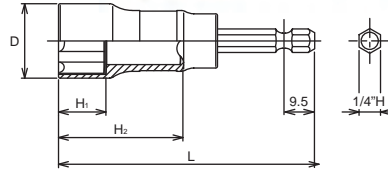

BD014E-SF

Surface Drive Nut Setters, deep
Surface Drive Steckschlüsselklingen, lang
Douilles longues, Surface Drive

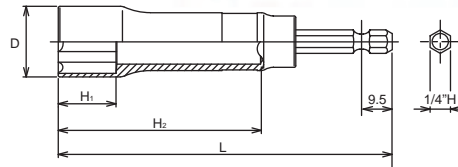

BD008E-165

12-point Nut Setter, extra long
12-kant Steckschlüsselklinge, extra lang
Douilles 12-pans à embout, extra longues

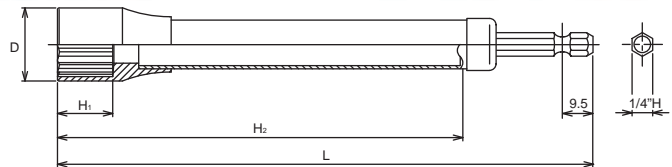

BD011SE

12-point Universal Joint Nut Setters
12-kant Steckschlüsselklingen mit Gelenk
Douilles 12-pans articulées à embout

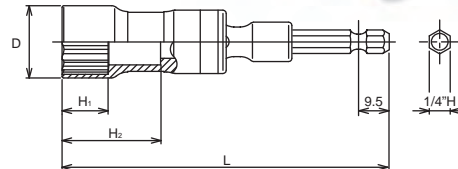

184E-64





Drill Chuck Adaptor
Bohrfutteradapter
Adaptateur de mandrin de perçage

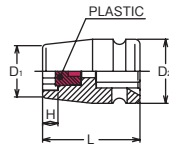

Z-SERIES
 HAND
 TITANIUM
 SCREWDRIVERS ACCESSORIES
 IMPACT
 SLEEVE-DRIVE
 PROTECTOR
 INDUSTRIAL
 AUTOMOTIVE
 MOTORCYCLE
 CONSTRUCTION
 SPARE PART

BD14400MJ  6-point Sockets for Anchor Screws
 6-kant Steckschlüssel
 Douilles 6-pans





BD14400MJ (mm)		D ₁ (mm)	D ₂ (mm)	H (mm)	L (mm)	 (g)	 (pcs.)	
13	1/2"	20.7	25	5	38	140	10	*1
15		23.2	30	5	38	145	10	*2
16		24.5	30	6.5	38	145	10	*2
17		25.7	30	6.5	38	145	10	*2
19		28.2	30	7.5	38	145	10	*2

*1 C-Ring=C41, Pin/O-Ring=A41/B41
 *2 C-Ring=C42, Pin/O-Ring=A42/B42  **P268-269**

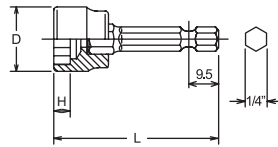
BD016E  6-point Sockets for Anchor Screws
 6-kant Steckschlüsselklingen
 Douilles 6-pans à embout pour vis d'ancrage





BD016E (mm)	D (mm)	H (mm)	L (mm)	 (g)	 (pcs.)
13	19.5	4	50	43	10
17	24.5	5	50	56	10
19	27	6	50	68	10

 **DIN 3126 Form E 6.3**

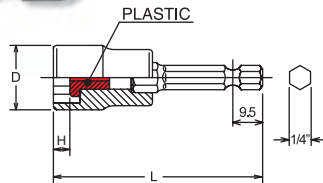
BD016JE  6-point Nut Setters with Plastic Stops
 6-kant Steckschlüsselklingen mit Plastik-Anschlag
 Douilles 6-pans à embout avec arrêt en plastique



BD016JE (mm)	D (mm)	H (mm)	L (mm)	 (g)	 (pcs.)
13	19.5	5	60	66	10
17	24.5	6.5	60	80	10
19	27	7.5	60	90	10

 **DIN 3126 Form E 6.3**

BD017E Wing Bolt Socket for Electric Drill
 6-kant Steckschlüsselklingen für Flügelschrauben
 Douilles 6-pans à embout pour ecrous à oreilles

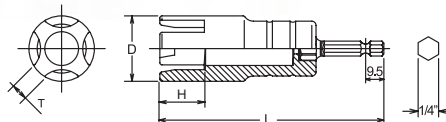

BD017E	D (mm)	T (mm)	H (mm)	L (mm)	 (g)	 (pcs.)
	31	7.3	21	104	158	10

 **DIN 3126 Form E 6.3**



BD018		D (mm)	T (mm)	H (mm)	L (mm)	(g)	(pcs.)	
	$\frac{3}{8}''$	31	7.3	21	45	113	10	*2

*2 C-Ring=C32, Pin/O-Ring=A32/B32 → P268-269

BD018 Wing Bolt Socket
Steckschlüssel für Flügelschrauben
Douilles pour écrous à oreilles

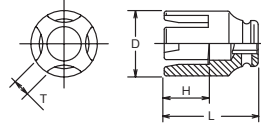

3119		T ₁ ×T ₂ (mm)	D ₁ (mm)	D ₂ (mm)	d (mm)	L (mm)	(g)	(pcs.)
3 x5	$\frac{3}{8}''$	3 x5	17	17.3	11	30	30	10
5.5x6		5.5x6	21	19.5	14	33	45	10



For Wing Bolt
Für Flügelschrauben
Pour écrous à oreilles



For Drain Plug in Radiator
Für Kühler-Ablassschrauben
Pour le vidange du radiateur

3119 Wing Bolt Socket
Steckschlüssel für Flügelschrauben
Douilles pour écrous à oreilles

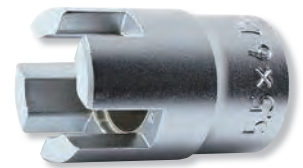
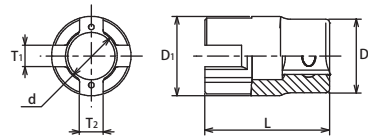

162E (mm)	D (mm)	L (mm)	(g)	(pcs.)
8	23	66	82	10
10	27.9	66	107	10

162E (inch)	D (mm)	L (mm)	(g)	(pcs.)
1/4	23	66	83	10
5/16	23	66	82	10
3/8	27.9	66	107	10
1/2	27.9	66	108	10

◆ DIN 3126 Form E 6.3

162E Stud Setters
Stehbolzeneindreher
Monte-goujons

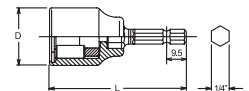
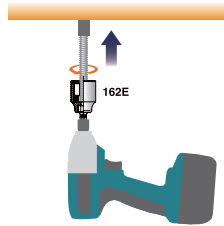

BD004 (mm)		D ₁ (mm)	D ₂ (mm)	L (mm)	(g)	(pcs.)
12.5x10	$\frac{1}{2}''$	30	25	70	236	5
12.5x13		38	30	75	388	5
12.5x16		38	30	75	369	5
20 x19	$\frac{3}{4}''$	48	44	90	775	2
20 x22		48	44	90	752	2
20 x25		62	44	95	1184	2
20 x29		62	44	95	1148	2



BD004 Impact Screw and Stud Setters
Impact Stehbolzeneindreher
Monte-goujons, Impact

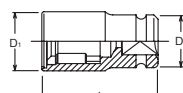

BD022-120P

Hammer Drill Adaptor
 Adapter für Schlagbohrmaschinen
 Adaptateur pour alésoeurs

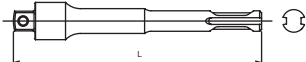

BD022-120P		L (mm)		
3/8	3/8"	120	100	10
1/2	1/2"	120	160	10

BD023E

Adaptors
 Verbindungsstücke
 Adaptateurs

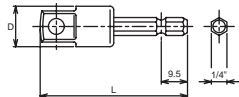

BD023E		D (mm)	L (mm)		
3/8	3/8"	12.5	55	27	10
1/2	1/2"	16.5	60	48	10

◆ DIN 3126 Form E 6.3

BD024E

Universal Adaptors
 Gelenk Adapter
 Augmentator articulé

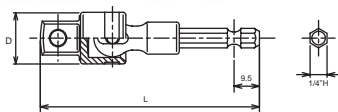

BD024E		D (mm)	L (mm)		
3/8	3/8"	19.3	78	63	10
1/2	1/2"	19.3	82	73	10

◆ DIN 3126 Form E 6.3

170S (mm)	D (mm)	T (mm)	L (mm)	(g)	(pce.)
10x12	34	38	250	260	1
12x14	34	38	250	260	1

171S (mm)	D (mm)	T (mm)	L (mm)	(g)	(pce.)
14x17	44.6	50	250	460	1
17x19	44.6	50	250	460	1
17x21	44.6	50	250	460	1
19x21	44.6	50	250	460	1

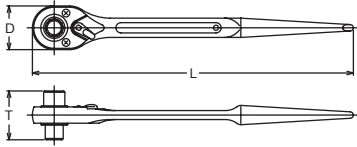

170S ○ Spud Handle Ratchets, reversible
Doppelseitige Gerüstbauknarre, umstellbar
Cliquets, réversibles, pour assemblage et démontage -
échafaudages, manche pointu

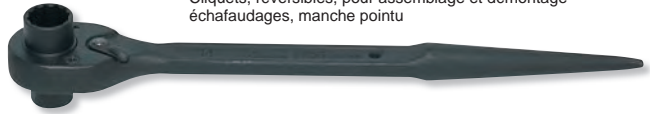

171S ○ Spud Handle Ratchets, reversible
Doppelseitige Gerüstbauknarre, umstellbar
Cliquets, réversibles, pour assemblage et démontage -
échafaudages, manche pointu



171 ○ Spud Handle Ratchets (Long), reversible
Doppelseitige Gerüstbauknarre, lange Ausführung, umstellbar
Cliquets longs, réversibles, pour assemblage et démontage -
échafaudages, manche pointu

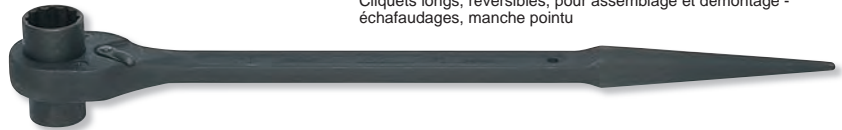

171 (mm)	D (mm)	T (mm)	L (mm)	(g)	(pce.)
14x17	44.6	50	380	630	1
17x19	44.6	50	380	630	1
17x21	44.6	50	380	630	1
19x21	44.6	50	380	630	1

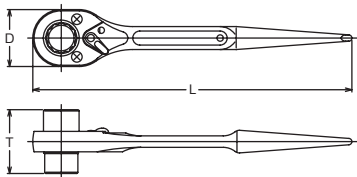

172 ○ Spud Handle Ratchets (Long), reversible
Doppelseitige Gerüstbauknarre, lange Ausführung, umstellbar
Cliquets longs, réversibles, pour assemblage et démontage -
échafaudages, manche pointu



172 (mm)	D (mm)	T (mm)	L (mm)	(g)	(pce.)
21x26	68	58	380	1100	1
22x24	68	58	380	1100	1
23x26	68	58	380	1100	1
24x27	68	58	380	1100	1
26x32	68	63	380	1100	1

171SB-1/2	(mm)	D (mm)	T (mm)	L (mm)	(g)	(pce.)
1/2"	44.6	33	250	480	1	

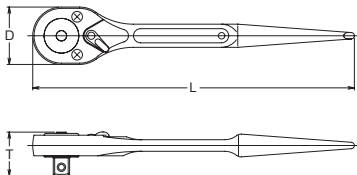

171SB-1/2 Spud Handle Ratchet with Push Button (short)
Gerüstbauknarre mit Arretierungsknopf (kurz)
Cliquet d'échafaudage avec bouton de verrouillage (court)



171B-1/2	(mm)	D (mm)	T (mm)	L (mm)	(g)	(pce.)
1/2"	44.6	33	380	650	1	

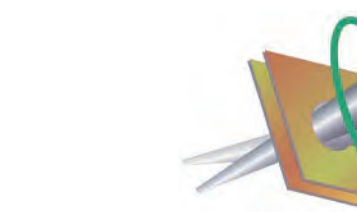

171B-1/2 Spud Handle Ratchet with Push Button (long)
Gerüstbauknarre mit Arretierungsknopf (lang)
Cliquet d'échafaudage avec bouton de verrouillage (long)

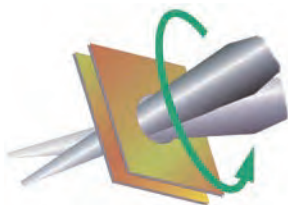

Twin Opening Spud Handle Ratchets
The tapered handle is designed to align bolt holes in flanges, rivet holes or similar assemblies.

Knarren mit doppelseitiger Steckschlüssel-Kombination und konischem Griff für die Ausrichtung von Bohrlöchern z. B. an Flanschen und Gerüsten.

Cliquets à tête double avec manche conique pour aligner les trous des boulons lors des travaux d'échafaudage ou de tout travail de construction.